

CIE Pro

# CIE Pro: The Intelligence Engine for Next-Generation Calibration

Faster, Smarter, and Fully Integrated.  
The modern platform to replace your legacy toolchain.

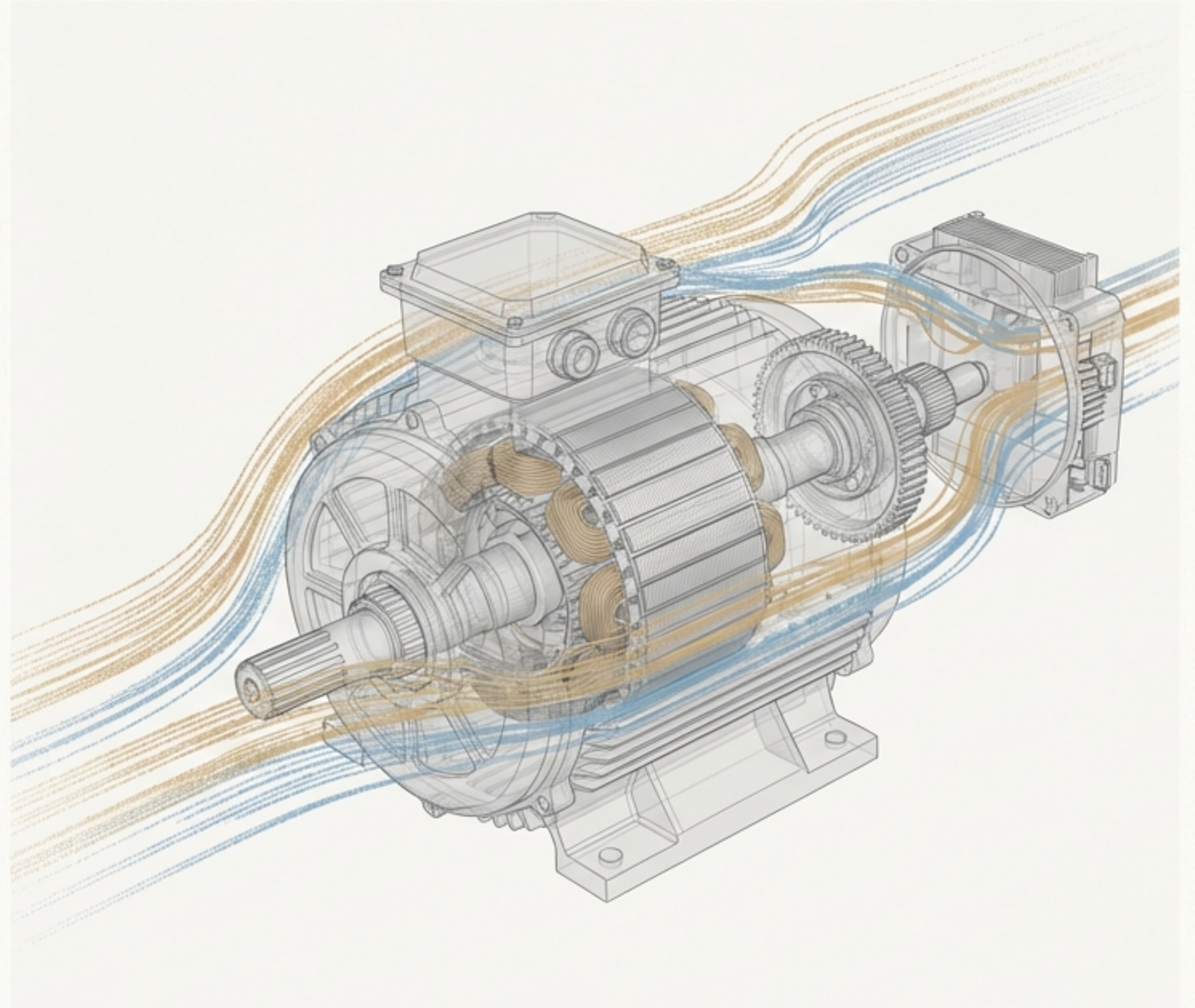

# Today's Calibration is a Battle Against Complexity.

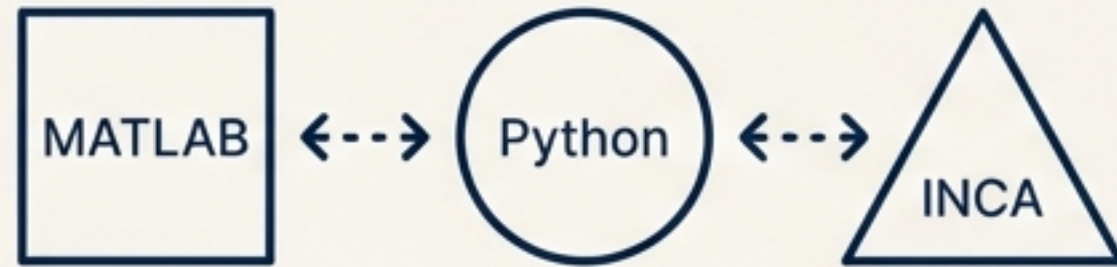

## Fragmented Toolchains

Juggling separate, disconnected tools for DoE, modeling (MATLAB/Python), and ECU flashing/data acquisition (INCA/CANape). Creates data silos and manual handoffs.

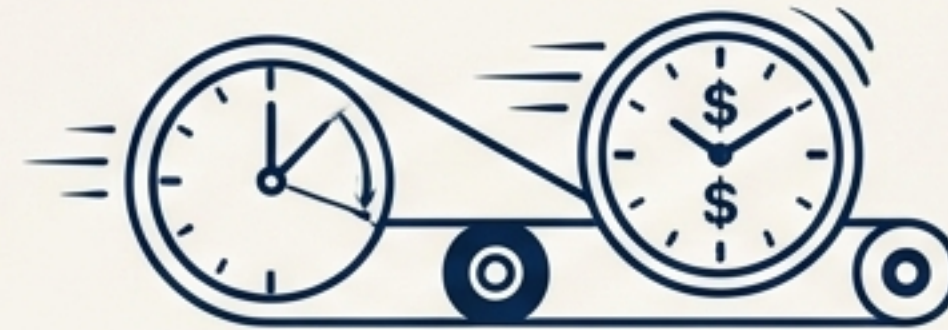

## Expensive Test Cycles

Inefficient static DoE plans lead to excessive and costly dyno and on-road testing. Active learning is not available, and test plans don't adapt.

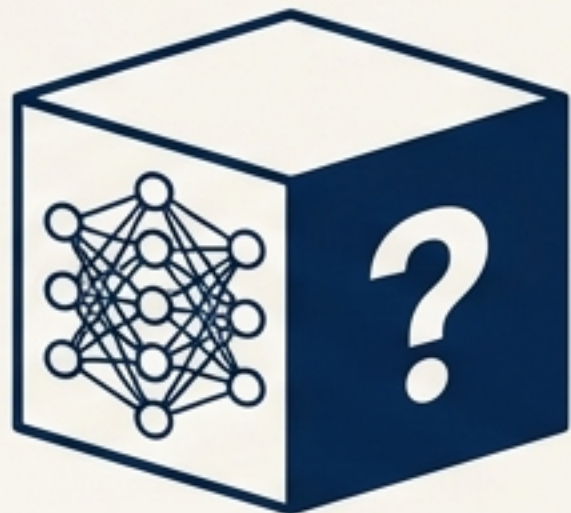

## Black-Box Models

A lack of trust and interpretability in model outputs from traditional ML tools hinders critical engineering decisions and regulatory compliance.



## Legacy Platforms

Desktop-bound, Windows-only software that stifles collaboration, requires complex installation & licensing, and is not built for modern, distributed teams.

# A Single, Intelligent Platform for the Entire Workflow.

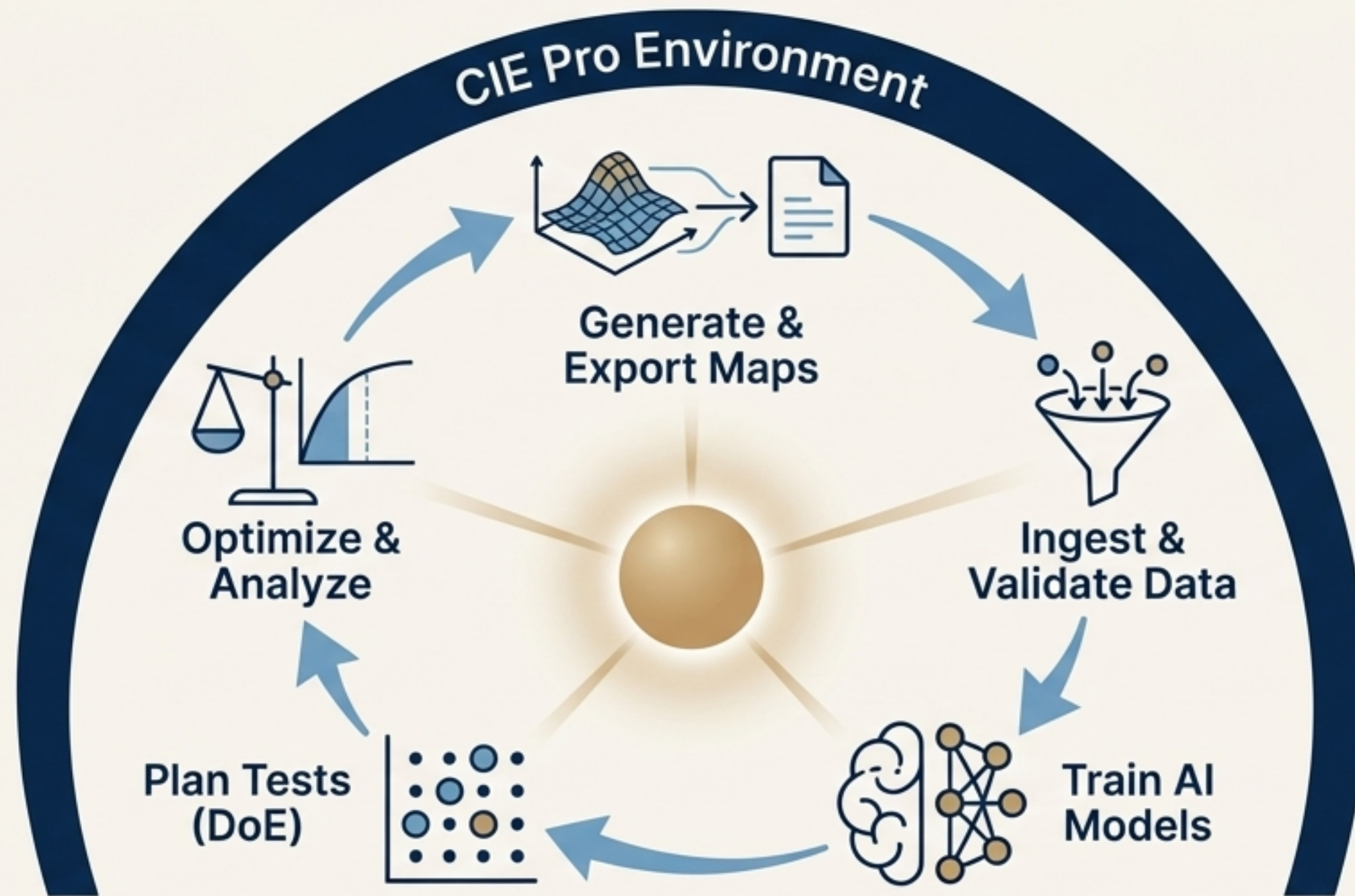

CIE Pro unifies every step of the calibration process—from data ingest to ECU export—powered by a modern, web-based, AI-first architecture.

# Ingest, Validate, and Understand Your Data Instantly.

## Multi-Format Ingest

Drag-and-drop support for industry-standard formats. No manual conversion needed. Includes: CSV (comma, semicolon, tab), Excel (.xlsx, .xlsm), and native dyno formats like ASAM MDF. Also supports MATLAB (.mat) and HDF5.

## Automated Signal Decoding

Robust, automatic extraction of all numeric signals. Intelligently handles metadata, non-numeric columns, and empty values. Detects metadata rows in Excel and cleans 'Unnamed' columns.

## Instant Quality Assurance

Immediately view summary statistics, identify missing values, and preview data tables to ensure quality before modeling begins. The system automatically detects and flags constant features (zero variance) that can cause model training failures.

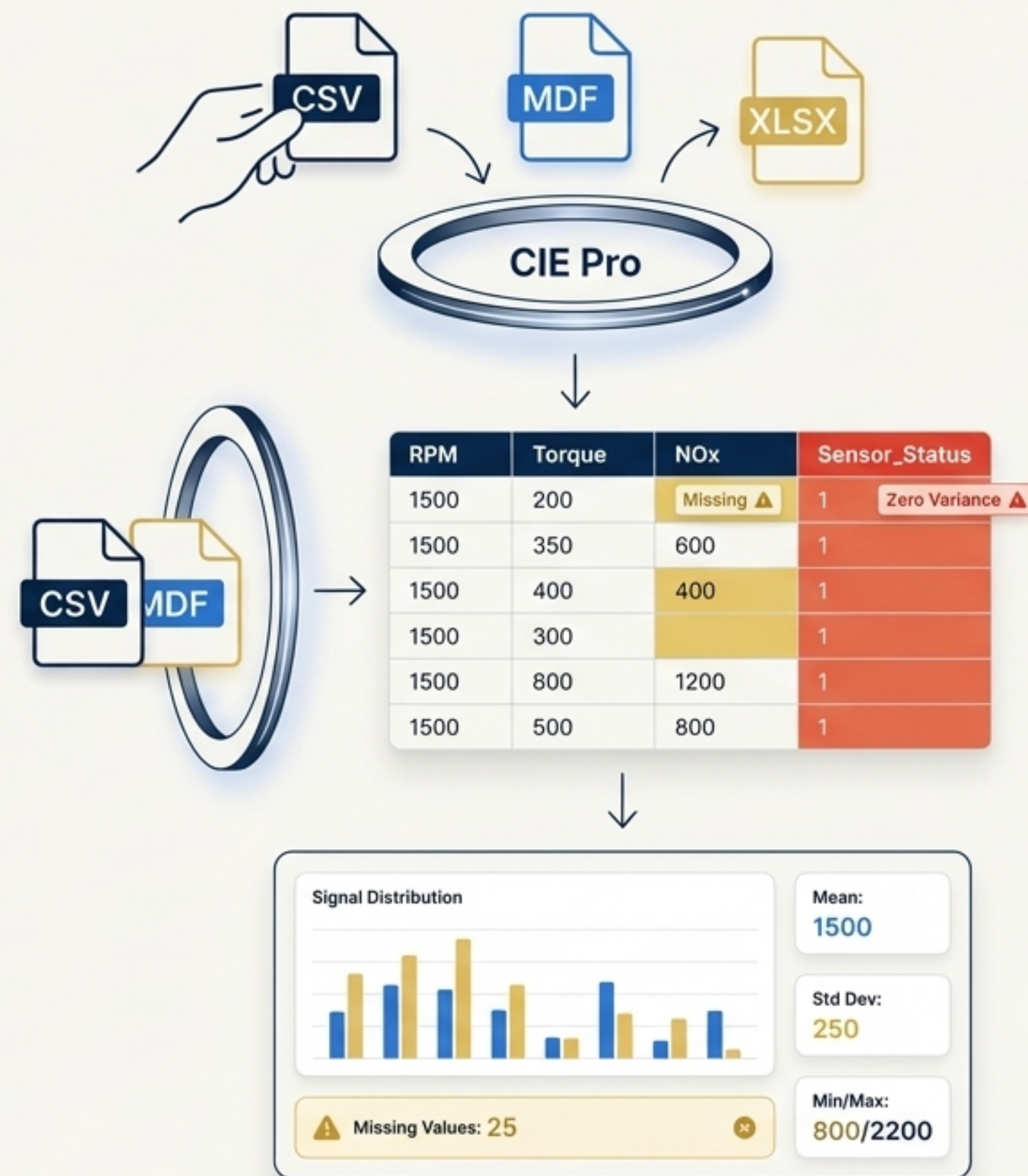

# Train Production-Grade Models in Minutes, Not Days.

## World-Class Model Suite

Access a full library of surrogates, including Random Forest, Gradient Boosting, Gaussian Processes (for uncertainty), and advanced models like Radial Basis Function (RBF) and Polynomial Chaos Expansion (PCE).

## AutoML with Optuna

Automatically find the optimal model architecture and hyperparameters for your specific dataset. The engine intelligently performs model selection and cross-validation with pruning to achieve the best performance.

## Built-in Validation & Quality

Ensure model reliability with integrated cross-validation (5-fold default) and quality checks designed to exceed  $R^2 > 0.95$ . The platform provides rich metric cards showing  $R^2$ , RMSE, and MAE.

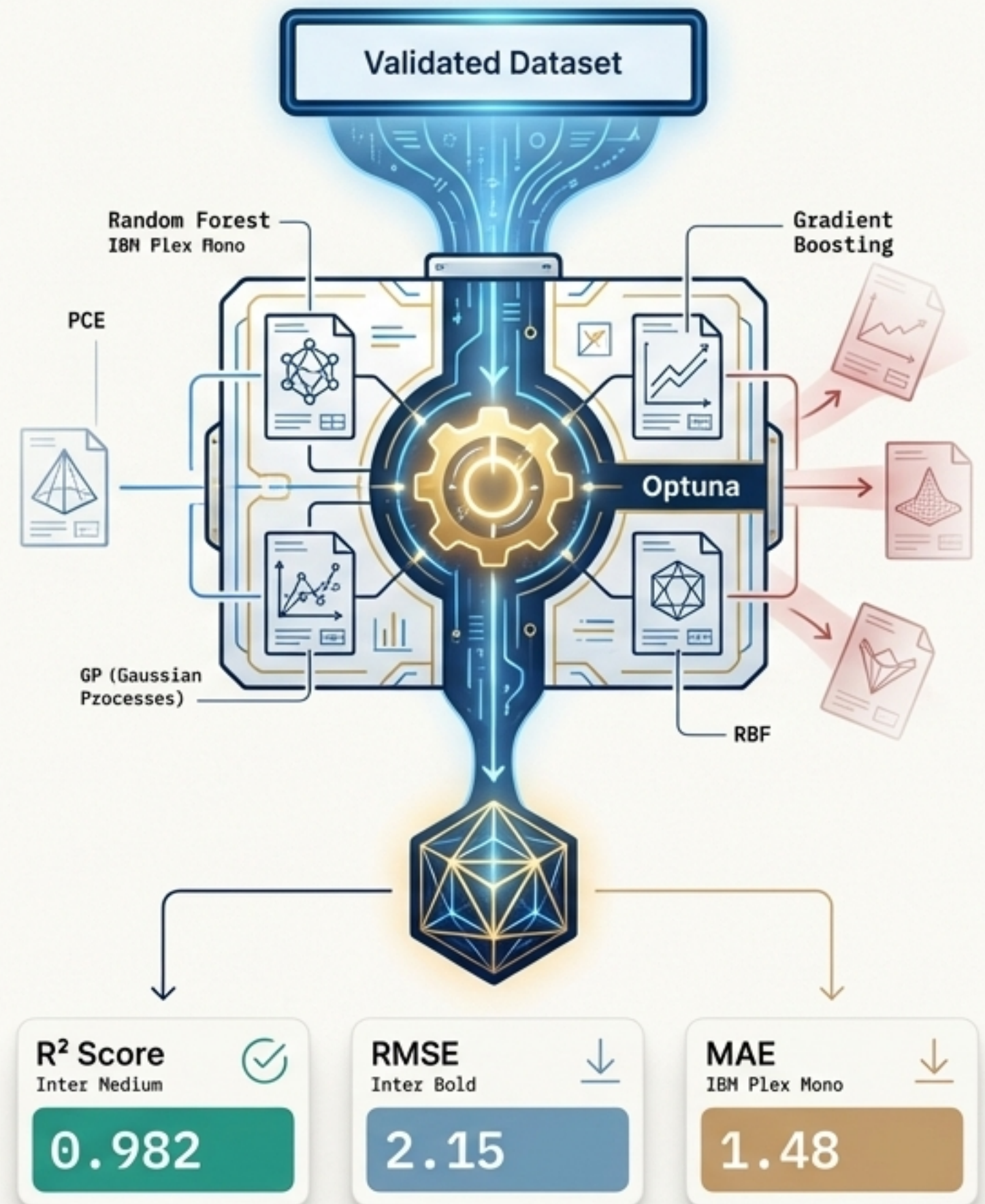

# Slash Dyno Time with Smarter Design of Experiments.

## Reduce required test points by 30-50%



### Comprehensive Static DoE

Generate optimal, space-filling test plans for steady-state mapping.

- Methods: D-Optimal, Latin Hypercube Sampling (LHS), Sobol Sequence, Full Factorial, Central Composite, and Box-Behnken

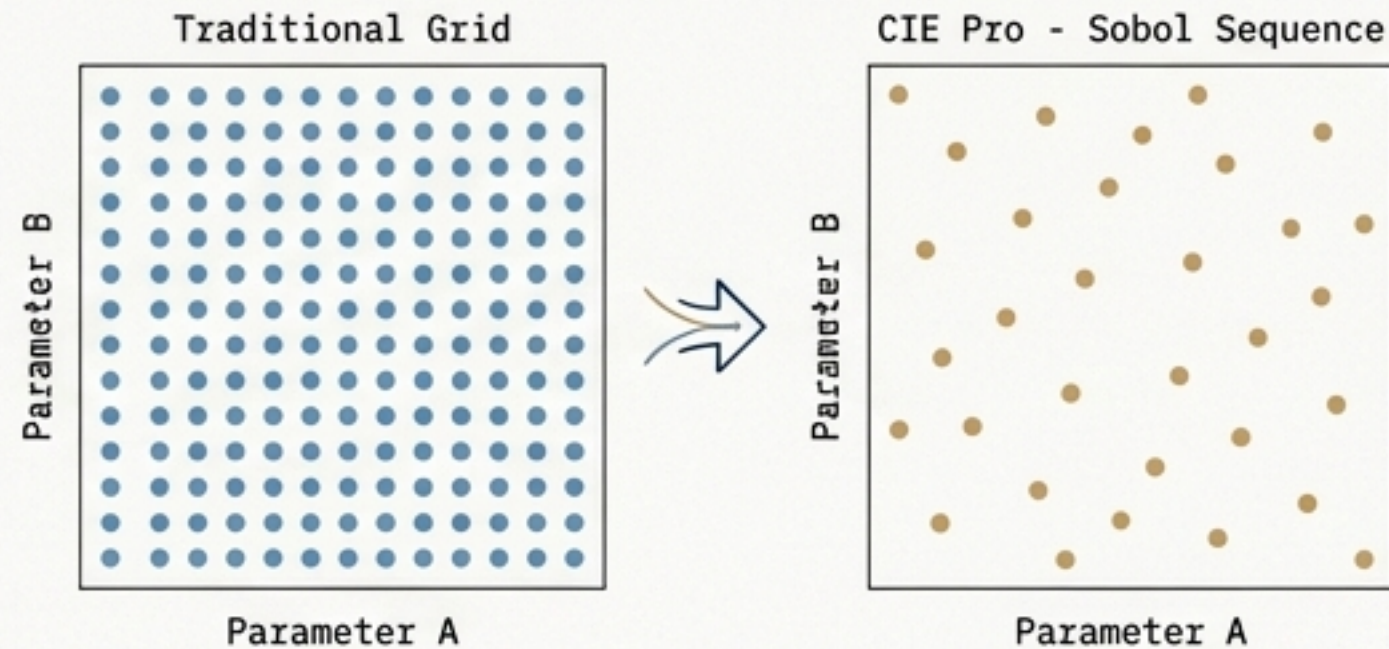

### Dynamic DoE for Transients

Create time-based test sequences with sinusoidal frequency sweeps to accurately capture transient system behavior.

- Features: Set operating envelopes, safety limits (including rate limits), and convex hull constraints to stay within valid operating regions.

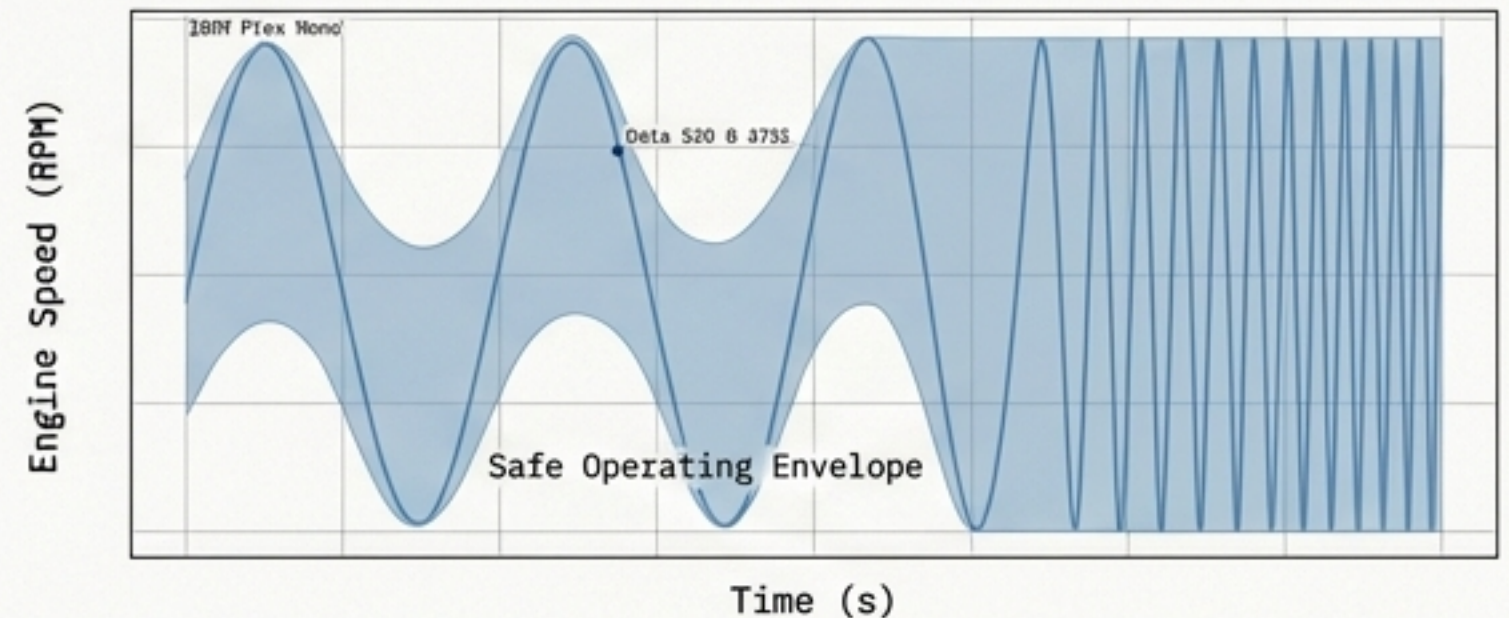

### Future-Ready

Built with a code-ready infrastructure for Active Learning to intelligently guide future testing toward the most critical operating regions, further minimizing test time.

# Solve Complex Multi-Objective Problems with Confidence.

**Achieve 50-70% faster convergence to the optimal solution.**

## State-of-the-Art Optimizers

Leverage powerful algorithms like NSGA-II and CMA-ES to navigate trade-offs between conflicting objectives, such as maximizing performance while minimizing emissions and fuel consumption.

## Interactive Pareto Fronts

Visually explore the entire solution space in interactive 2D/3D plots. Empower engineers to make data-driven calibration decisions by understanding the trade-offs between every potential solution.

## Robust & Uncertainty-Aware

Find solutions that are not just optimal, but also reliable and robust to real-world operational variance by leveraging uncertainty-aware optimization methods.

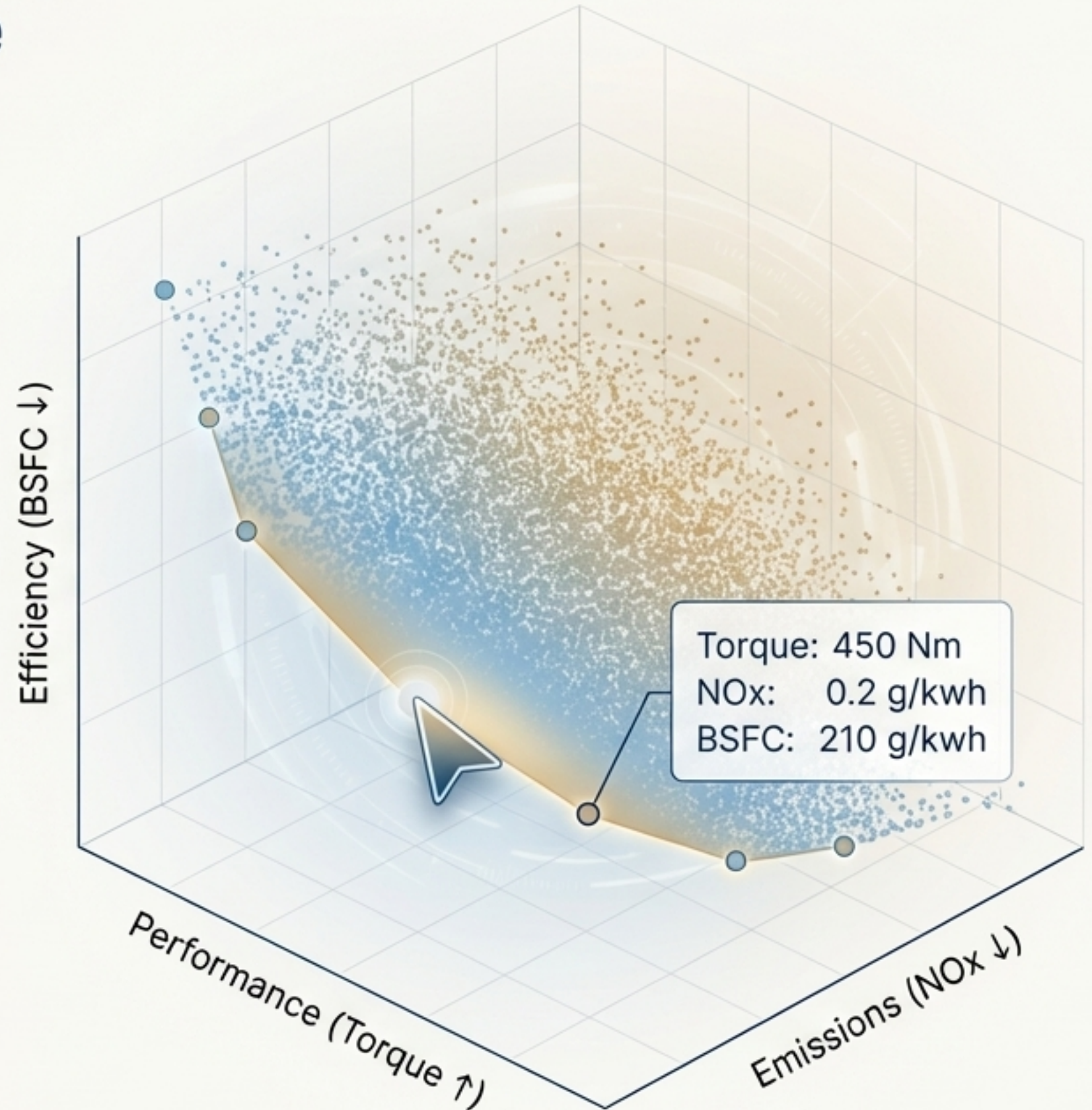

# Generate, Refine, and Export Production-Ready Calibrations

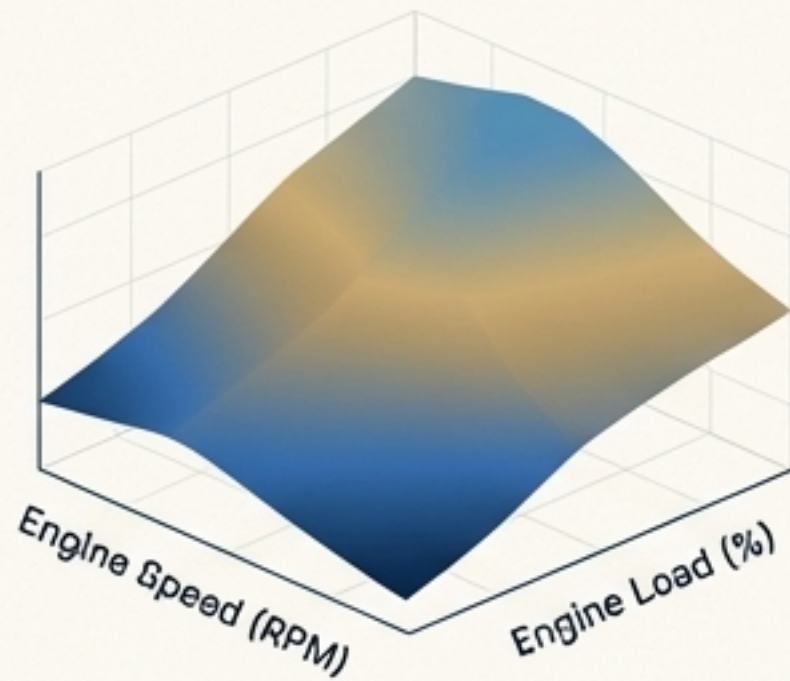

## Instant Map Generation

Create 2D/3D calibration maps (lookup tables) directly from your validated models with configurable resolution.

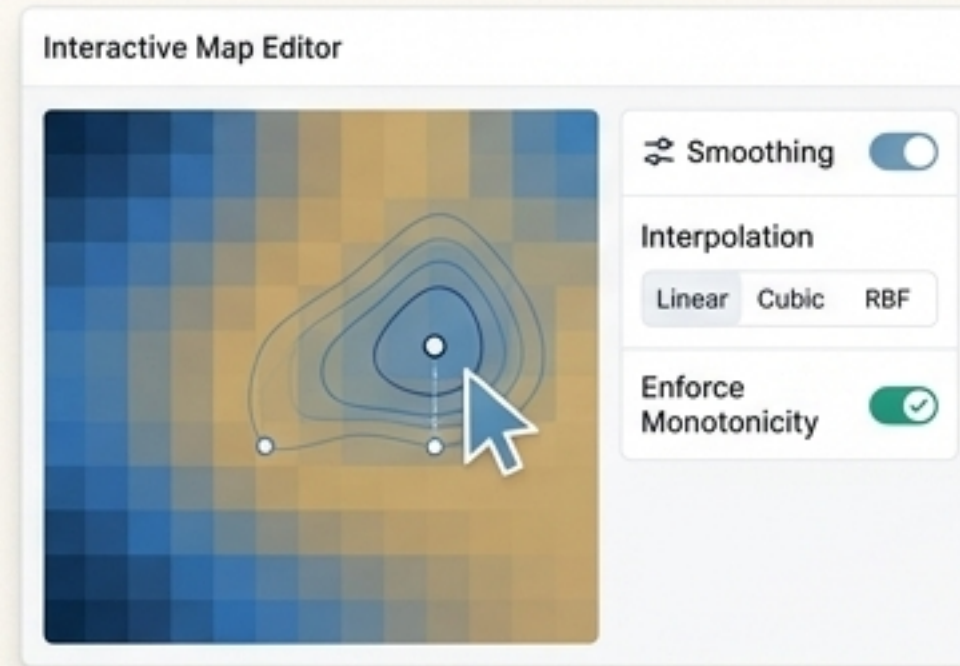

## Interactive Map Editor

Visually inspect, refine, and validate maps. Enforce physical constraints with powerful tools for Gaussian smoothing, interpolation (Linear, Cubic, RBF), and monotonicity enforcement.

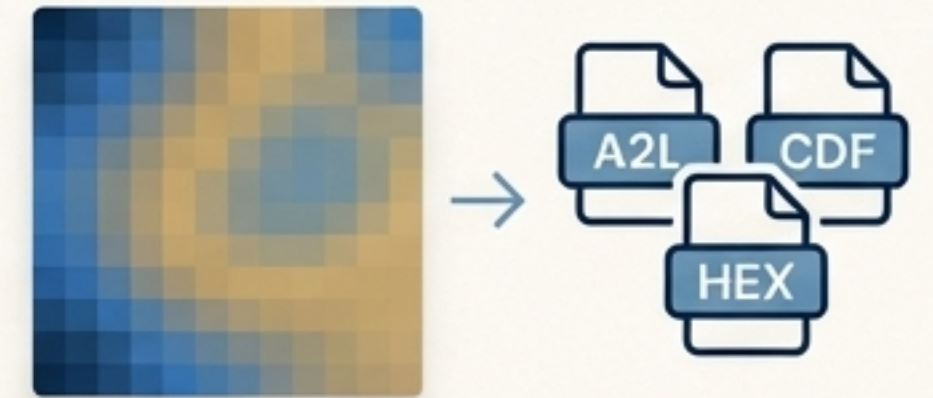

## Seamless Toolchain Export

Export directly to industry-standard ASAM formats (A2L, CDF, HEX) and connect with native, bi-directional integration for ETAS INCA and AVL CAMEO.

# More Than a Tool—An Intelligence Engine

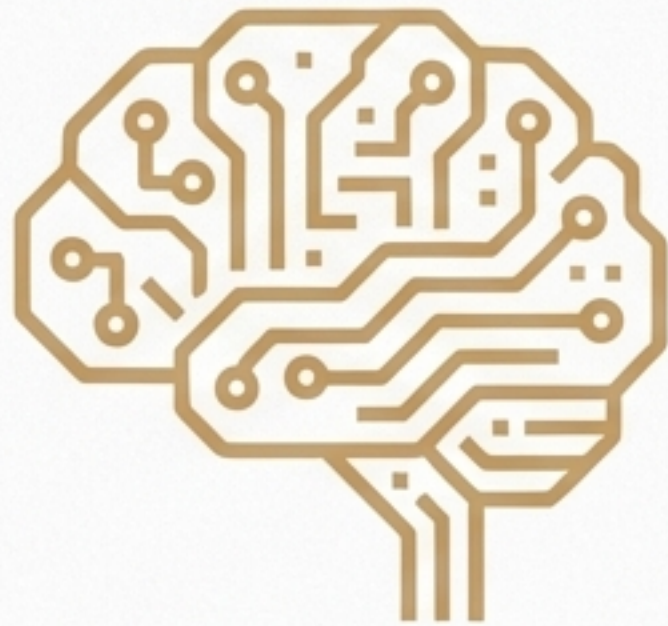

## Next-Generation AI/ML

Go beyond basic modeling with intelligent automation, uncertainty quantification, and explainability. This is the core of our competitive advantage.

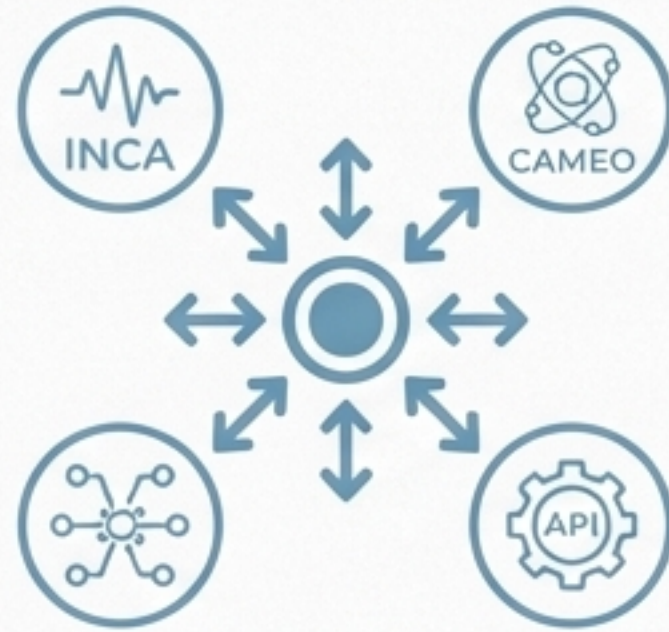

## Open & Integrated Ecosystem

Serve as the central hub for your entire toolchain with native integrations and a full RESTful API for extensibility.



## Modern Web Platform

Enable true collaboration with a zero-installation, cloud-native application accessible from any device, anywhere.

# Go Beyond Prediction with World-Class Machine Learning

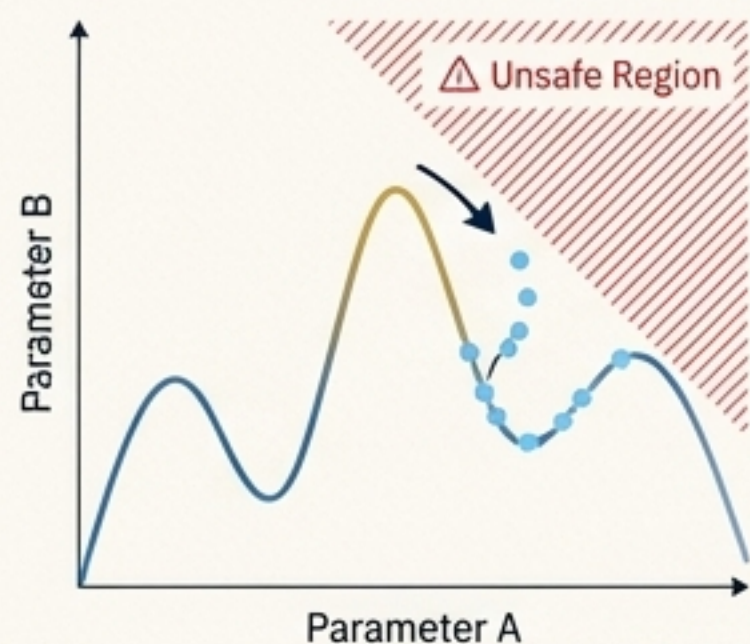

## Constrained Bayesian Optimization

Risk-aware automated calibration that respects safety limits and slashes test time by an average of 50-70%.

## Full Uncertainty Quantification

Calibrate for robustness. Move beyond point predictions to understand the confidence in every model output, enabling risk-aware decisions.

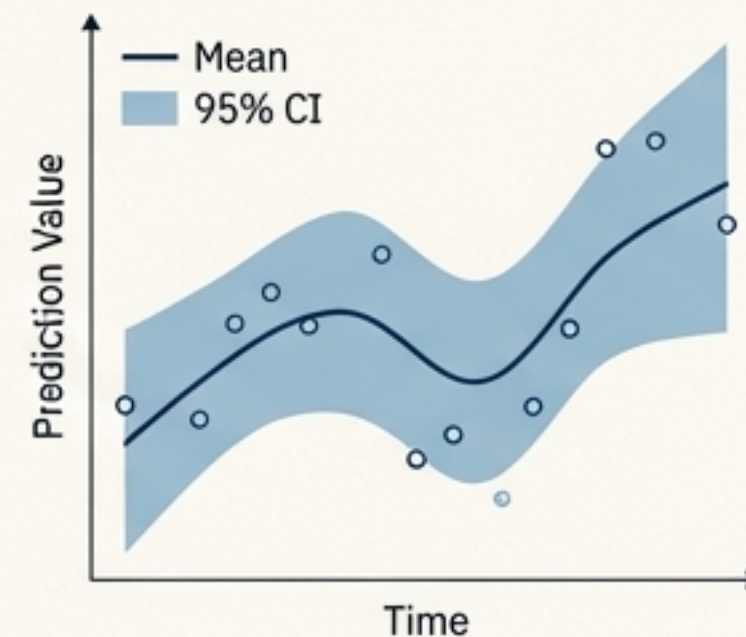

## Explainable AI (XAI)

Eliminate black boxes. Understand *why* your model makes a prediction with integrated SHAP and LIME, providing full model interpretability for debugging and compliance.

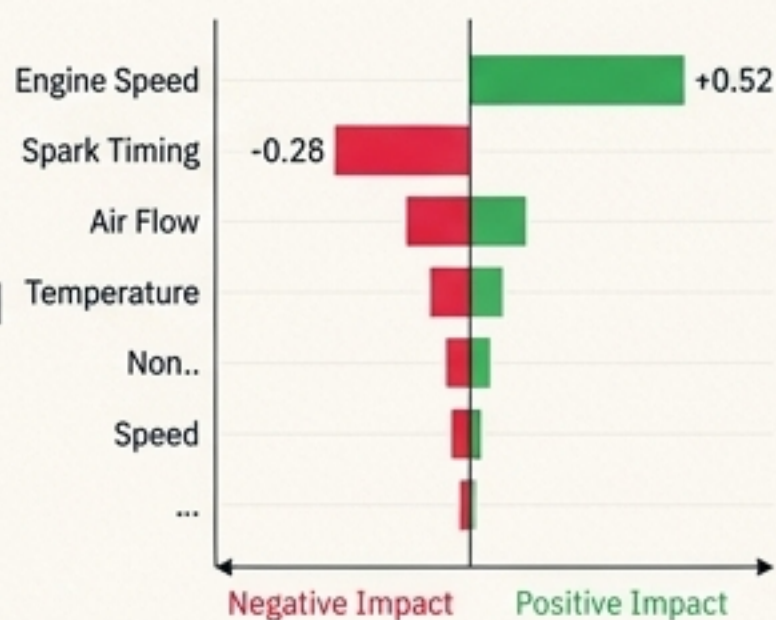

## Physics-Informed Neural Networks (PINNs)

A future-ready architecture to blend physical laws with sensor data for superior accuracy, especially with sparse datasets. (Code-ready for integration).

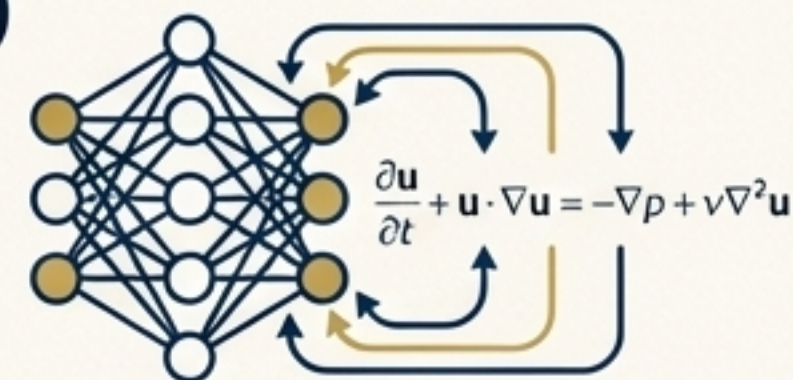

# Your Central Hub for Calibration Projects and Data.

## Deep Toolchain Integration

Native, bi-directional integration with **ETAS INCA** (COM interface and file-based) and **AVL CAMEO** (REST API and file-based) for a seamless workflow.



## Advanced Project Management

Manage the full project lifecycle with version control (Git-like snapshots), collaborator management, and project templates for standardization and repeatability.

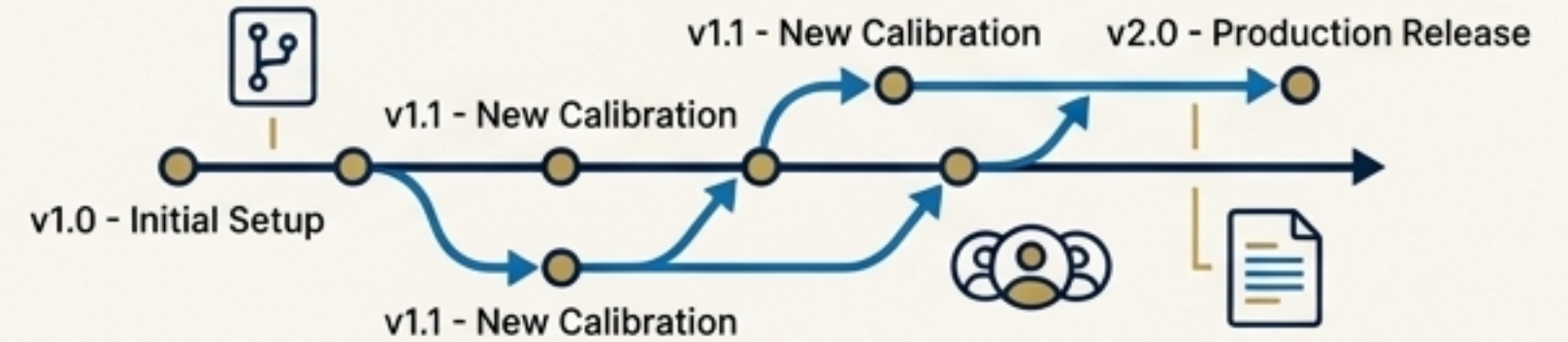

## Automated Professional Reporting

Generate comprehensive, shareable HTML and PDF reports with a single click to document and communicate findings effortlessly.















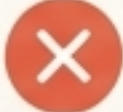

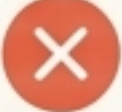
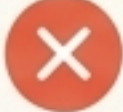
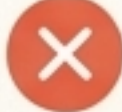

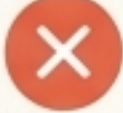
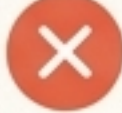

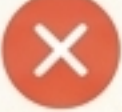
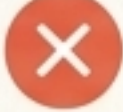
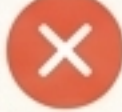

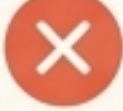
## Cloud-Native & Web-Based

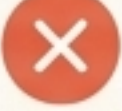
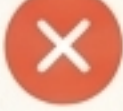
Access from anywhere, on any device. No installation or complex licensing required. Perfect for modern, distributed engineering teams.

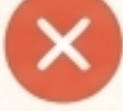

# CIE Pro vs. The Status Quo: A Generational Leap.

Feature	 CIE Pro	 AVL CAMEO	ETAS INCA	 MATLAB MBC
End-to-End Workflow (Unified Platform)				
Web-Based & Collaborative Platform				
Constrained Bayesian Optimization				
Explainable AI (XAI) with SHAP/LIME				
Full Uncertainty Quantification				
AutoML Integration (Optuna)				
Dynamic DoE for Transients				

# Built for Reliability, Ready for Your Most Demanding Projects.

## ✓ Comprehensively Validated

Achieved a 92.9%+ pass rate across all production readiness tests, with 100% of core features verified.

## ✓ Full Audit & Reproducibility

Ensure complete traceability and repeatability with comprehensive audit logging for all operations and configuration hashing for version control.

## ✓ Robust & Resilient

Engineered with comprehensive error handling for missing data, graceful degradation for optional dependencies, and clear, actionable user guidance.

## ✓ Enterprise-Grade Architecture

A well-organized, version-controlled codebase built on a modular, agent-based architecture designed for scalability and maintainability.

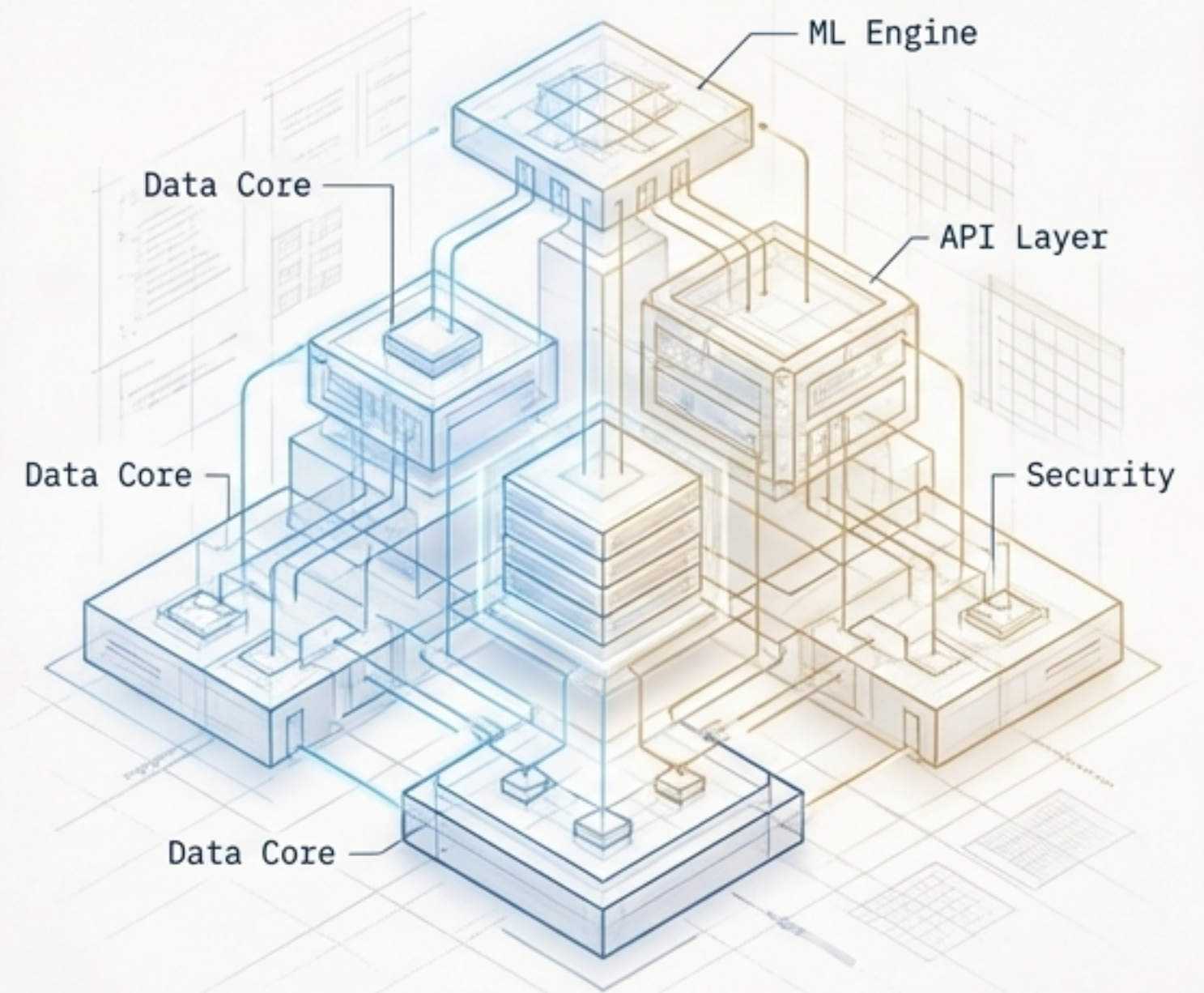

# Calibrate Faster, Smarter, and More Collaboratively.



## Reduce Test Time by up to 70%

with intelligent DoE, Constrained Bayesian Optimization, and multi-fidelity capabilities.



## Increase Confidence & Trust

with full uncertainty quantification and integrated Explainable AI (XAI) for fully interpretable models.



## Unify Your Entire Workflow

in a single, modern platform, eliminating data silos with seamless INCA & CAMEO integration.



## Empower Your Team

with a collaborative, web-based tool accessible from anywhere, with zero installation.



# CIE Pro

## Experience the Future of Calibration.

### Request a Personalized Demo

Let us walk you through a workflow with your specific use case.

### Start a Proof-of-Concept Trial

Test CIE Pro with your own data and see the results firsthand.

### Contact Us

[sales@ciepro.tech](mailto:sales@ciepro.tech) | [www.ciepro.tech](http://www.ciepro.tech)